



## TS971 based Electret Condenser Microphone amplifier

by R.CITTADINI & F.POULIN

This application note explains how to implement the TS971 as a microphone pre-amplifier for an Electret Condenser Microphone (ECM). This type of microphone has one of the best price to performance ratio on the market.

Microphone pre-amplifiers are very common in today's appliances, digital appliances have adopted and kept the typologies used in analog ones. This block is helping to interface the microphone to the A/D converter by buffering, filtering and amplifying the microphone signal.

### 1 - DEVICE PRESENTATION

Many low noise amplifiers exist in the market. Oldies (but still goodies!) are mainly dual ones like LM833, MC33078. But few are able to reach low voltages and are not available in today's smallest packages.

The TS97x is a family including single, dual and quad low-noise operational amplifier. It features excellent audio characteristics: low distortion (0.003% THD @ F=1kHz) and a 4nV/sqrt(Hz) equivalent input noise voltage with a 1/f corner @ 100Hz. Thanks to those characteristics, it helps keeping an optimal Signal to Noise ratio, a critical point at the entry of the audio amplification chain!

These devices also allows a higher fidelity thanks to a 4V/μs Slew Rate and 12 MHz Gain Bandwidth Product. This enables the amplifier to cope with quick variations of the input signal well over the audio bandwidth.

The family is available in compact packages like SOT23-5 for TS971 or even the thin and rather compact package like TSSOP for TS972/4. This allows them to be used in portable and miniature digital appliances like PDA or Cellular Phones and also in thin notebook computers.

Table 1: Acoustic Units Reference Table

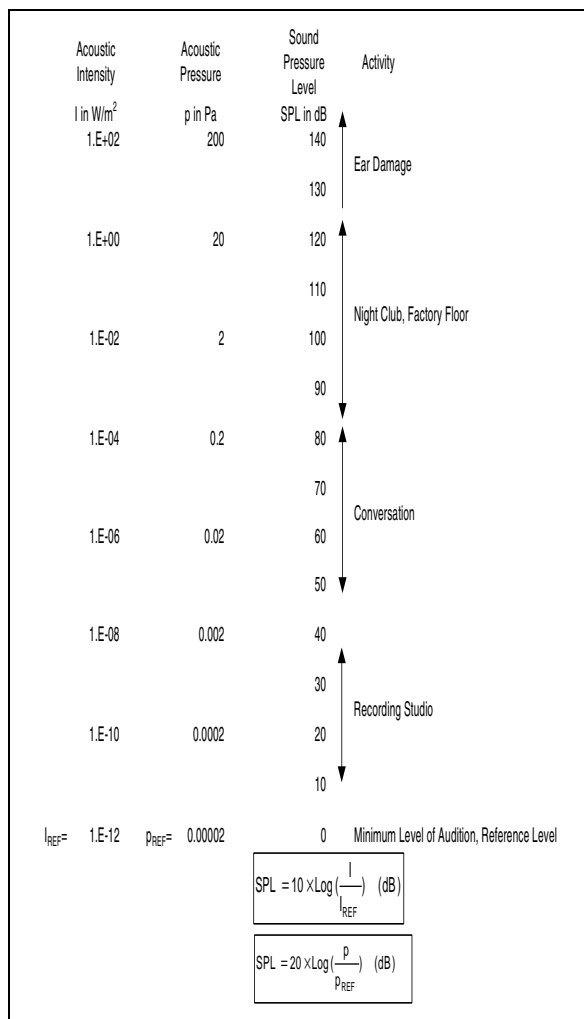

### 2 - MICROPHONE CONSIDERATIONS

Preliminary knowledge of Acoustic Intensity (in Watt/m<sup>2</sup>), Acoustic Pressure (in Pascal or Pa) and Sound Pressure Level or SPL (in Decibels or dB) is important. You can report to **table 1** for more information.

ECM microphones follow more or less the same characteristics, however Gain and surrounding components may vary from one model to another.

We selected a popular model from Panasonic: the WM-60A series. It's an omni-directional microphone with the following main characteristics:

- Operating: from 2 to 10V.
- Sensitivity: -44dB +/- 5dB (0dB=1V/Pa).
- Impedance: less than 2.2kΩ
- S/N ratio: more than 58dB
- Current Consumption: 0.5mA max
- Recommended Load Resistor:  $R_L$ : 2.2kΩ

The sensitivity of the microphone defines its gain as per the following formula:

$$G_{\text{mike}} = 10^{\left(\frac{\text{Sensitivity}}{20}\right)} \text{ (V/Pa)}$$

So with a -44dB sensitivity, we can conclude that the gain of the microphone is 0.0063V/Pa or 6.3mV/Pa. With this value, we can get a good idea of the output voltage of the microphone. It would be around 12.6μV for a quiet room (2mPa or 40dB) and would reach approximately 6.3mV for the climax of a symphonic orchestra (1Pa or 110dB). This sound data is with a source at 1 meter from the microphone. This reference is mandatory, the distance between the microphone and the audio signal is illustrated by the Acoustic Intensity (in Watt/m<sup>2</sup>).

Let's take the example of a conversation. It's equivalent to roughly 20mPa or 60dB SPL at 1 meter. So an Acoustic Intensity of 1μW and 126μV at the output of the microphone. The intensity decreases with the squared value of the distance between the source and the microphone. So for a distance of 5cm, you would get a value of 400μW. As per the **Table 1** formulas, we can calculate the "equivalent SPL value at 1m": 86dB, then we get the Acoustic Pressure: 0.4Pa which gives us the output of the microphone:

0.4 x 0.0063 = 2.52mV (distance divided by 20 and output voltage increased by the same ratio).

We can summarize these considerations into the following checklist:

- What type of signal do you want to amplify?
- How powerful? At what distance?
- What are the minimum and maximum of each above parameters?

With these values, you will be able to calculate the microphone's output voltage range and be able to choose the right gain of the amplifier hereafter.

Also, if you want to implement a noise canceling function, you can also choose another type of microphone called bi-directional microphone or noise canceling microphone.

### 3 - COMPONENTS CALCULATION

Let's look now on how to implement such an amplifier with TS971. You can refer to schematic on **Figure 1** hereafter. We've chosen a non-inverter topology to exploit to the best the low noise characteristics of the device. Indeed, with an inverter configuration, the input resistor adds significant noise to the application.

First, let's look on the behavior in DC mode. The first goal is to polarize the Electret Condenser Microphone. By using  $R_1$  and  $R_2$ , we can polarize it around  $V_{cc}/2$  as per below formula:

$$I_{\text{pol - mike}} \approx \frac{V_{cc}}{2 \times (R_1 + R_2)} \text{ (A)}$$

The only criteria is that this current must remain below 0.5mA over the supply range (otherwise, you can increase R1 value).

$R_1$  is also acting together with  $C_1$  as a filter for the power supply line of the microphone. Then in AC mode,  $C_1$  is fixing the gain of the microphone by allowing only  $R_2$  to act (and not  $R_2+R_1$  as  $C_1$  is equivalent to a short circuit to the ground). And  $R_2$  must equal  $R_L=2.2k\Omega$  for the microphone we've chosen. In AC mode, this type of microphone can be simplified and compared to a current source in parallel with  $R_2$ , hence a voltage source.

Then to avoid extra offset drift due to bias current mismatching, following resistor values need to comply with the following rule:

$$R_8 \approx R_4 + R_3 + \frac{R_5 \times R_6}{R_5 + R_6} \text{ (Ohms)}$$

The second step is, still in DC mode, to polarize the reference pin of the TS971. It's the inverting pin here that will be set at  $V_{cc}/2$  by the  $R_5$  and  $R_6$  bridge.  $C_4$  adds here additional filtering of this reference voltage. This configuration allows the biasing or the "centring" of the signal at mid-supply voltage. Hence it allows to maximize the swing within the supply voltage range. This bias voltage just needs to be kept within  $V_{ICM}$  range. This means  $V_{ICM}$  or Common Mode Input Voltage must be at least 1.15V inside the supply voltage rails, i.e. from  $V_{dd}+1.15$  to  $V_{cc}-1.15$ V.

Figure 1: ECM Microphone Pre-amp. with TS971

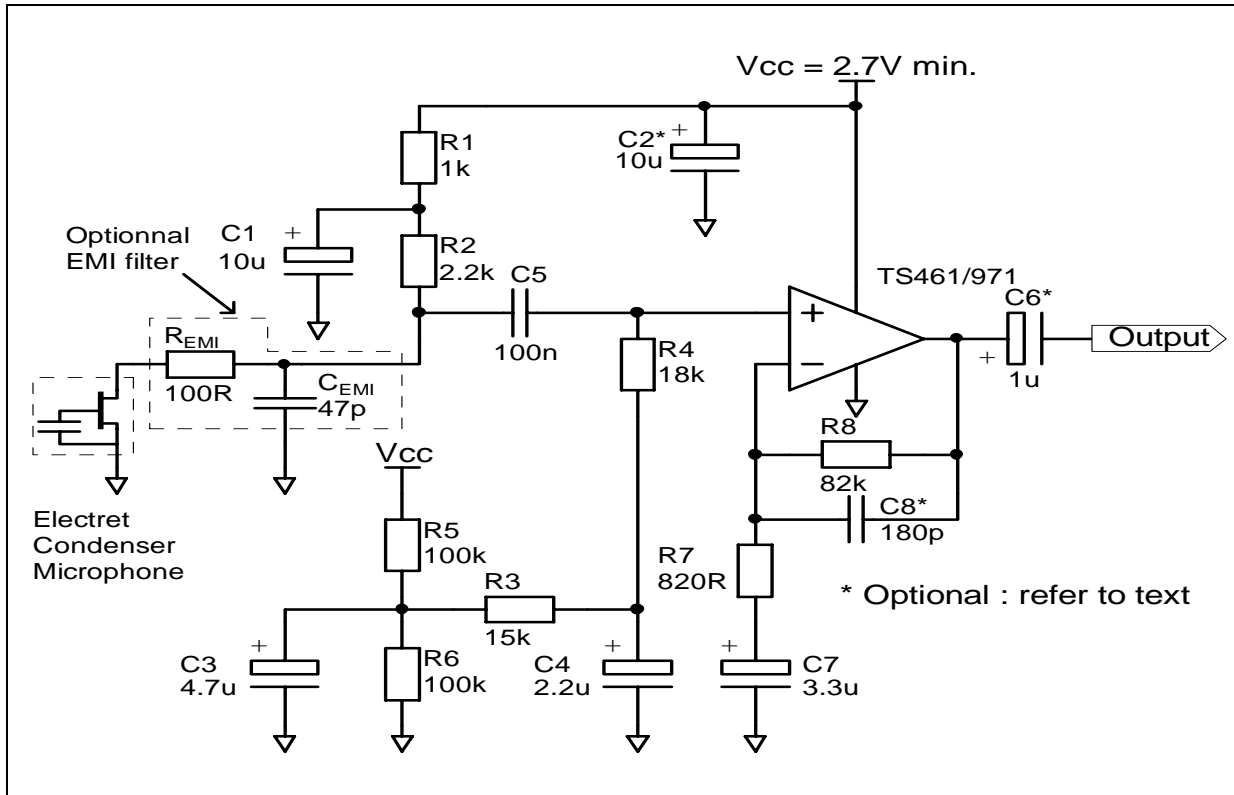

This bridge can also be supplied by an ASIC's "Vref out" pin or by another operator of the op-amp connected as a buffer (using the TS972, a dual op-amp, this can be implemented easily).

An important note on the impedance of the amplifier is that, in AC mode, R<sub>4</sub> is equivalent to the input impedance of the amplifier stage. It must not be too small to avoid the collapsing of the microphone signal!

The coupling capacitor (C<sub>6</sub>) makes this application universal, however, you could omit it when attacking an A/D converter. In this case, you only have to adapt the bridge set by R<sub>5</sub> & R<sub>6</sub> to match the input voltage range of the converter. Thanks to its Rail-to-Rail output, the TS971 simplifies the process.

We're coming now to the filter definition, when looking at **figure 1**, we can see three filters: two high pass and a low pass. Each has a 6dB/octave attenuation factor.

The high pass filter is built by C<sub>5</sub>, R<sub>4</sub> and also R<sub>2</sub>. The theoretical formula to calculate F<sub>CL</sub> or the

Lower Cutoff Frequency (here approximately 79 Hertz) is the following

$$F_{CL1} \approx \frac{1}{2 \times \pi \times (R_2 + R_4) \times C_5} \quad (\text{Hz})$$

Another high pass filter is made by C<sub>7</sub> and R<sub>7</sub>. The cutoff frequency is better set at a lower value than F<sub>CL</sub> to have a stronger reduction (i.e. -12dB/octave) of low frequencies (here 59Hz).

$$F_{CL2} \approx \frac{1}{2 \times \pi \times R_7 \times C_7} \quad (\text{Hz})$$

Then for the low pass filter (optional), to calculate F<sub>CH</sub> or the Higher Cutoff Frequency (here approximately 10.7kHz), we have the following formula::

$$F_{CH} = \frac{1}{2 \times \pi \times R_8 \times C_8} \quad (\text{Hz})$$

The next step is to configure G or the gain of the amplifier (here 90 or +39dB):

$$G \approx \left(1 + \frac{R_8}{R_7}\right) \times \left(\frac{R_4}{R_4 + R_2}\right) \times \text{Gain of the microphone}$$

This represents the gain of the amplifier in the "non-filtered" bandwidth area.  $R_2$  and  $R_4$  have to be taken into consideration as they establish a voltage divider. Changing  $R_7$  value helps to modify the gain without being forced to change the values of the other components (apart from the high pass filter with  $C_7$ ).

What we refer to as the "gain of the microphone" is the gain we talk about in the "Microphone considerations" chapter. You need to consider the signal fed to the microphone to avoid saturation or insufficient gain.

To be completely exhaustive, if you use  $C_6$ , you have to consider that it creates together with the impedance of the load  $Z_L$  a high pass filter with cutoff frequency defined like above (replacing  $R_4$  with  $Z_L$  and  $C_5$  with  $C_6$ ).

**4- SPECIAL NOTE ON EMI**

As you can notice on Figure 1, we have suggested an optional Electro Magnetic Interference filter (cutting frequencies above 33.8MHz). With cellular phones being a constant company to our daily life, high power RF interferences need to be properly managed into sensitive amplification devices. This filter has to be implemented close enough to the microphone and we also have to pay attention on not having too long connecting wires (antennas!). Ideally this application should be wired on a

double sided PCB with one side acting as ground plane.

**5 - COMPONENTS CALCULATION**

So, in this example, we have a gain value of 90 or +39dB and we have globally a band pass filter with  $F_{CL} \sim 60-80\text{Hz}$  and  $F_{CH} = 10.7\text{kHz}$ . Concerning the overall gain, we also have also to consider the stage after the pre-amplifier. If it's a CODEC or A/D converter, it will most probably have its own amplification (usually +20dB gain). All together, this gives the below chain for the chapter 1 example:

Stage \ $V_{OUT}$	at 1 meter	at 5 cm
Microphone Output	0.13mV (126 $\mu$ V)	2.5mV
TS971 Output (+39dB)	0.11mV (11.34mV)	0.23V
Codec Output (+20dB)	0.11V	2.27V

This configuration is well adapted to battery powered equipment as the overall maximum consumption of this application is 3.3mA (0.5mA for the microphone and 2.8mA max for TS971).

Information furnished is believed to be accurate and reliable. However, STMicroelectronics assumes no responsibility for the consequences of use of such information nor for any infringement of patents or other rights of third parties which may result from its use. No license is granted by implication or otherwise under any patent or patent rights of STMicroelectronics. Specifications mentioned in this publication are subject to change without notice. This publication supersedes and replaces all information previously supplied. STMicroelectronics products are not authorized for use as critical components in life support devices or systems without express written approval of STMicroelectronics.

© The ST logo is a registered trademark of STMicroelectronics

© 2002 STMicroelectronics - Printed in Italy - All Rights Reserved  
STMicroelectronics GROUP OF COMPANIES

Australia - Brazil - Canada - China - Finland - France - Germany - Hong Kong - India - Israel - Italy - Japan - Malaysia  
Malta - Morocco - Singapore - Spain - Sweden - Switzerland - United Kingdom - United States

© <http://www.st.com>

