How to implement an SCR or a Triac in hybrid relay applications

Introduction

This document gives some key information about the design of the solid-state silicon AC switch stage of a hybrid relay, which can drive resistive, capacitive or inductive AC loads, such as: heater resistors, motors for industry, power tools or appliance applications.

[Section 1](#) describes the hybrid relay principle. Circuit and functional diagram is the first topic to be handled followed by its advantages and drawbacks and finally the main targeted applications are listed.

[Section 2](#) specifies different ways to drive the AC switch implemented on the hybrid relay circuit.

[Section 3](#) provides some design tips to pass electromagnetic compatibility standards, especially to reduce EMI noise.

Contents

1 Hybrid relay..... 5

 1.1 General schematic 5

 1.2 Advantages and drawbacks 6

 1.3 Applications..... 7

 1.3.1 Water and room heaters..... 7

 1.3.2 Home automation smart plug 7

 1.3.3 Inrush limiter for power supply 7

 1.3.4 Three-phase motor 8

2 SCR / TRIAC insulated control 10

 2.1 Insulation requirement..... 10

 2.2 AC switch quadrants 11

 2.3 Insulated control circuits..... 12

 2.3.1 Opto-triac..... 12

 2.3.2 Transformer 14

 2.3.3 Opto-transistor..... 15

 2.4 Solutions sum-up 15

 2.5 Insulated control versus hybrid relay applications 16

3 EMI conducted noise management..... 18

 3.1 V_{FP} phenomenon..... 18

 3.2 Design advice to decrease EMI noise 19

4 Conclusion..... 21

5 Revision history 22

List of tables

Table 1: Triggering quadrants for each AC switch family and class.....	12
Table 2: Insulated control circuits advantages and drawbacks	15
Table 3: Insulated circuits versus hybrid relay applications.....	16
Table 4: Document revision history	22

List of figures

Figure 1: Hybrid relay principle	5
Figure 2: Hybrid relay for inrush current limitation function	8
Figure 3: Hybrid relay examples for 3-phase grid	8
Figure 4: Example of a functional Triac insulated control circuit	10
Figure 5: Safety insulation requirement	11
Figure 6: Triac quadrant definition	12
Figure 7: Triac controlled with an opto-Triac	13
Figure 8: SCRs controlled by an opto-triac	14
Figure 9: Triac controlled by a pulse transformer	14
Figure 10: Triac controlled by an opto-transistor	15
Figure 11: Hybrid relay turn-off (a) – zoom on Triac turn-on (b)	18
Figure 12: VFP for a negative switched current	19
Figure 13: Relative variation of gate trigger current versus junction temperature	20

1 Hybrid relay

The hybrid relay consists of a couple of switches placed in parallel to drive a single load to an alternative network. This is a mechanical switch, a relay, in parallel with a solid-state silicon AC switch, i.e. a Triac or an SCR. Advantages of each device are merged to obtain a robust solution concerning AC load driving reliability and performance.

1.1 General schematic

The figure below shows the general schematic and the sequence diagram of a hybrid relay based on a Triac in parallel with a mechanical switch.

Figure 1: Hybrid relay principle

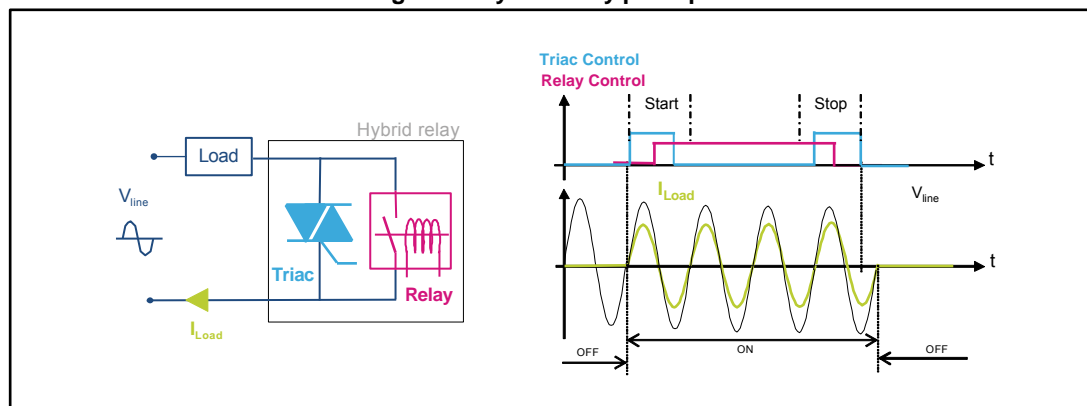

On the right figure above, the diagram shows how each switch is controlled to drive the load.

Load conduction (ON time in the figure sequence) can be described in three phases, the start phase, the full conduction and the stop phase.

Start-phase:

- First of all, the Triac is turned ON. Then, the line voltage is applied to the load. There are two reasons to start the Triac first. The fast response time of this device (few nanoseconds) allows the load to be started when the voltage across the hybrid relay is close to zero to limit electromagnetic interference (EMI, see next [Section 1.2](#)). On high inrush current inductive loads, the silicon structure is preferred and it can absorb repetitive high current peaks. In addition, a Triac can be triggered in phase-shift mode for a better management of the inrush current (see [Section 1.3.3](#) for inrush current limiter application).
- After few line voltage cycles, the relay is also turned ON. Now the current flows through the mechanical switch that has a lower resistivity than the silicon one. The Triac can be stopped.

Conduction phase :

- The load current flows only through the relay while the Triac is off. The advantage is to decrease power losses of the switch during this phase.

Stop phase :

- The Triac is once again driven. Due to the relay low resistivity, the current still flows through it. The relay is now turned OFF. The current passes through the Triac. It

allows the voltage across the hybrid relay to be kept a low when the mechanical switch is opened and avoids possible flashes among relay contacts.

- Finally, The Triac is turned OFF. The current flows until next zero-current due to the latching structure of this kind of silicon switch.

There are many ways to build a hybrid relay according to application requirements relative to line voltage, load current, environments etc, but the sequence is always the same.

1.2 Advantages and drawbacks

Using this hybrid relay based on both components (relay/Triac) instead of a single switch, have the following benefits:

- Power efficiency:
Thanks to the low relay contact resistance, the conduction loss is very low compared to a solution with a Triac only.
- Relay reliability:
With the previously explained sequence, the mechanical relay switches when the voltage across it is low, as the Triac keeps on conducting. Moreover, the load inrush current is detected by the silicon switch, safely thanks to its high current capability. It also increases the relay lifetime, which only drives steady-state current. Finally, there is not any mechanical relay bounce.
- Load reliability:
Solid-state technology allows a progressive soft-start or soft-stop to be fulfilled. A smooth motor acceleration and deceleration reduces mechanical system wearing and avoids any kind of damage to applications like pumps, fans, tools or compressors. For example, water hammer phenomena disappears in pipe systems, and V belt slippage could be avoided as jitter with conveyors.
- EMI noise reduction:
Thanks to Triac commutation at ZVS for the start phase and the turn-off at zero-current, the application is strongly immune against electromagnetic interference conducted noise (probably thanks to the fast response time of the silicon switch). It meets EN55014 standard for household appliances, electric tools and etc.
- Save volume:
Compared to a solution with a single switch, Triac can be used without any heatsink as it only conducts during the load inrush. SMD package can be used. Relay is also sized for nominal conducting current only (no need of a current overrating to withstand high reliability performance).
- Fast response time:
Thanks to the silicon switch, the hybrid relay can be closed quickly (Triac turn-on time is close to 100 ns), and then it is useful in those applications requiring immediate triggering as an uninterruptible power supply.
- Spark-free operation:
When Triac is ON, relay switching avoids possible sparks due to contact opening with high voltage, which reduces relay lifetime in application that requires many switching cycles. As there is no spark in normal working, this hybrid relay is compatible with applications in flammable environment, either in industrial (e.g. gas and toxic products in proximity of a motor machine) or residential (e.g. kitchen tools close to gas distribution). Hybrid relay helps to fulfill safety standards relative to flammable environments. Note that in high explosive environment (flammable and explosive environments are defined in ATEX EU directive 94/9/CE), hermetically sealed relay must be used (imposed by the IEC60079 standard regarding equipment protection), because of a risk of spurious relay triggering when Triac is OFF - then unwanted sparks can appear in case of electromagnetic interferences.

To obtain a robust AC switch design with a hybrid relay, there are three minor concerns:

Two devices, instead of one, have to be implemented, even if these switches are smaller. The switch command is a little bit more complex, but easily implemented thanks to an MCU already available in a lot of hybrid relay applications. Insulated Triac control: for safety purpose (see [Section 2.1](#)) or for three-phase applications (see [Section 1.3.4](#)), an insulated control of the Triac is required. Most common Triac insulated gate circuits are given in [Section 2](#).

1.3 Applications

Hybrid relay can be suitable in a wide range of applications where a robust design concerning electromagnetic compatibility and thermal performance is required. A non-exhaustive list is given below.

1.3.1 Water and room heaters

The circuit design given in [Figure 1](#) suits water and room heaters for domestic purposes, on a single phase grid network (see dedicated [Section 1.3.4](#) for three-phase grid application).

To fulfil EMC standard for domestic applications like: European standard EN55014-1, a single Triac could be used for commutations at zero-current, but for thermal dissipation reasons on these high power applications (0.5 kW to 3.7 kW / 230 V), a hybrid relay also suits to ensure the switching function.

Furthermore, to regulate water or ambient temperature, the heater resistor is driven to PWM mode and this means a lot a switching cycles. Therefore a hybrid relay is often preferred to keep reliability.

A Triac example for a 3.7 kW / 230 V room heater: T1635H-6G. A Triac in a D²PAK SMD package to gain space and to absorb high current. To use in parallel with a standard 16 A relay.

1.3.2 Home automation smart plug

A smart plug is an AC load controller, which can switch ON and OFF any load placed on the power grid.

The main constraint is to place this small box either on the wall or added to the mains plug externally. The saved volume and the low dissipation, (as no heatsink for Triac is required) are two important advantages.

Another constraint is that the load is completely unknown. It could be resistive (heater), inductive (transformer) or capacitive (low consumption lamps like LED). In all cases, thanks to its Triac, the hybrid relay is able to withstand high inrush currents.

A Triac example for a 2 kW / 230 V smartplug : T1210-800G. A Triac in a D²PAK SMD package fits size constraints and with a 800 V (useful for capacitive load), added to a strong turn-off commutation (asked by inductive load as universal motor). To use in parallel with a standard 10 A relay.

1.3.3 Inrush limiter for power supply

When a power supply is plugged on the grid, the bulk capacitor of the AC-DC converter is charged from a null voltage until the maximum line voltage. Without inrush current limitation, either there is a risk to break the relay during the first half-cycle due to overcurrent, or relay has to be hugely oversized. Moreover, IEC 61000-3-3 international EMC standard asks for maximum inrush levels to limit the line voltage fluctuation.

[Figure 2](#) shows the schematic of a hybrid relay suited to an AC-DC converter application with a start-up sequence on the right side.

Figure 2: Hybrid relay for inrush current limitation function

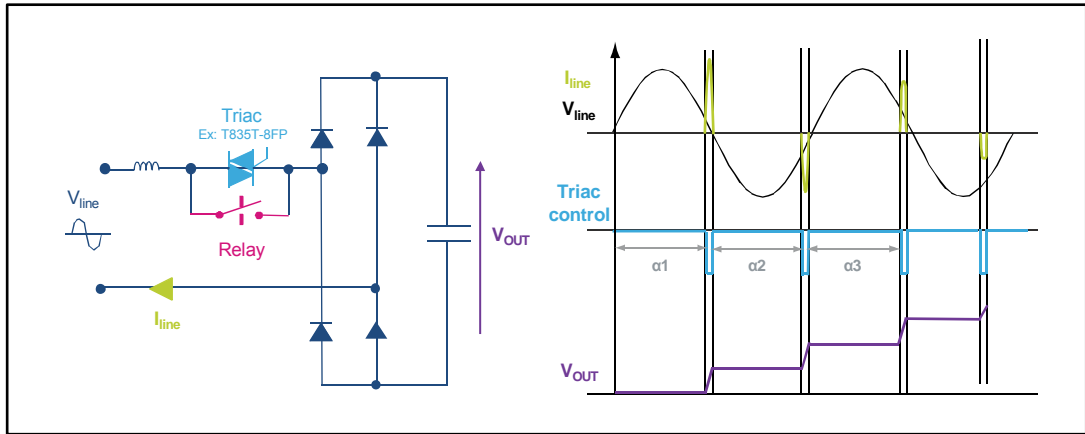

To limit the inrush currents below standard levels, Triac is controlled in phase-shift mode as shown on the sequence. In others words, Triac is triggered at the end of the line half-cycle (after a delay of α_1 , starting from the line zero voltage switching). It allows the charge of the capacitor to be limited to a low level in a first time, and then the charge current to be limited. In the next half-cycle, Triac is triggered with a shorter delay (α_2), and then the capacitor is charged until a higher voltage. This sequence is repeated until the capacitor is charged at the maximum line voltage.

Once the capacitor is fully charged, there is no more inrush current, thus the relay could be used for the dissipation concern for the steady-state current.

The Triac needs an insulated control because its reference (A1, cf AN3168 for Triac pin definition) is not a power supply, therefore it is not able to provide gate to A1 current to drive the Triac. Please refer to section 3 for insulated control possibilities.

A Triac example for a 1 kW / 230 V power supply in home appliances: T835T-8FP, with a high maximum junction temperature ($T_j \text{ max.} = 150 \text{ }^\circ\text{C}$) to avoid heatsink. To use in parallel with a standard 5 A relay. By considering an AC-DC converter above 1 kW, a mixed-controlled bridge with two SCRs and two diodes instead of the full diodes bridge should be preferred over hybrid relay, refer to AN4606 about inrush current limitation circuits).

1.3.4 Three-phase motor

Figure 3 shows two additional cases of hybrid relays. These designs are given for a 3-phase power line.

Figure 3: Hybrid relay examples for 3-phase grid

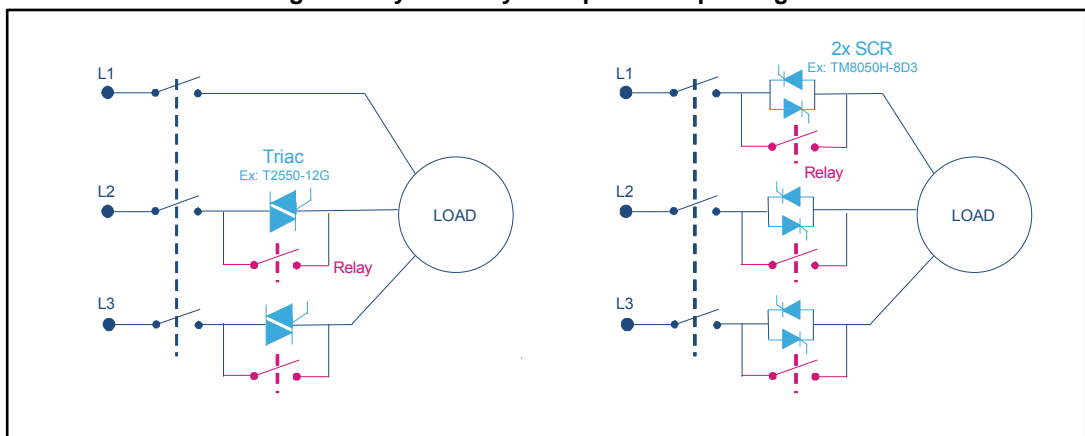

On the left of [Figure 3](#), two Triacs and two relays operate a hybrid relay function, they drive current flow through the three-phase. This topology is used for heater to increase relay lifetime and for mid-power motor applications (e.g. fans) where the inrush current has to be managed.



Line cut-off relays are not mandatory, they are used for safety purpose.

A Triac example for a 5 kW / 550 V industrial motor starter: T2550-12G. A 1200 V Triac for 3-phase grids, can withstand high inrush current of the motor and with a strong turn-off capability for these high currents. To use in parallel with a standard 25 A relay.

On the right side of [Figure 3](#), the same kind of application is shown but this time with two SCRs in back-to-back instead of Triac. For high power applications (e.g. for industrial motor starter), which require high turn-off commutations, it is recommended to use SCRs having any turn-OFF capability limitation, i.e. the SCR is always well turned OFF whatever the load rate of current is, (di/dt) OFF, when a Triac has a limitation, called (di/dt)_C parameter.

In this case, the three-phase grids are controlled by a hybrid relay in order to obtain a good sharing of power sunk from each line (current is always sunk from L1 in the schematic with Triac).

For these topologies, once again, an insulated control of the SCR or the Triac is mandatory.

An SCR example for a 5 kW / 550 V motor starter: TM8050H-8D3 in SMD D³PAK package for 400 V 3-phase grids or TN5050H-12WY in TO247 package for 550 V industrial 3-phase grids. Both are suitable to withstand high inrush currents and are designed for high temperature environments (T_J max. = 150 °C). To use in parallel with a standard 25 A relay.

2 SCR / TRIAC insulated control

For hybrid relay applications where SCR or Triac insulated control is required, as in the case of the inrush current limitation of a power supply or for three-phase applications seen previously, there are several possibilities to achieve the gate insulation.

Figure 4 gives an example of a hybrid relay application, where the control part (MCU) is placed in the insulated output of an AC-DC converter (e.g. a flyback). To ensure a functional insulation between low voltage DC side and Triac gate triggering in AC side, an insulated control circuit has to be implemented.

Figure 4: Example of a functional Triac insulated control circuit

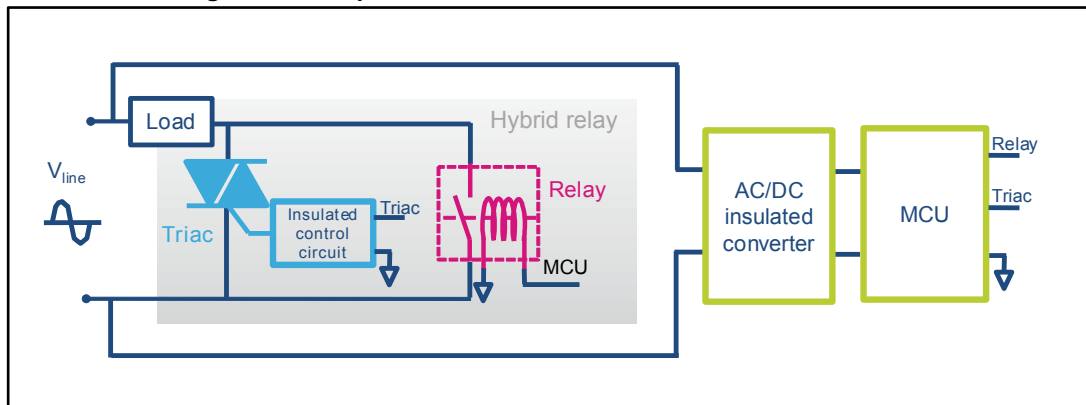

The following paragraphs provide those main circuits, which can be used to control a Triac in a hybrid relay, after a reminder of Triac turn-on quadrants. In all schematics, there is not any relay as it also could be used for a single Triac control and not necessarily for a hybrid relay application.

2.1 Insulation requirement

Hybrid relay applications where Triac or SCR gate circuit needs an insulation are split into two categories. In the first category, insulation is mandatory due to schematic, indeed when Triac A1 pin is not referenced to a power supply reference. This is the case for 3-phase applications or for inrush current limitation applications as seen previously (respectively in [Section 1.3.4](#) and in [Section 1.3.3](#)). This is the functional insulation shown in [Figure 4](#).

The second category meets safety standard and ensures electrical insulation of the user. The application requires in some cases an insulation of the silicon switch.

Figure 5: Safety insulation requirement

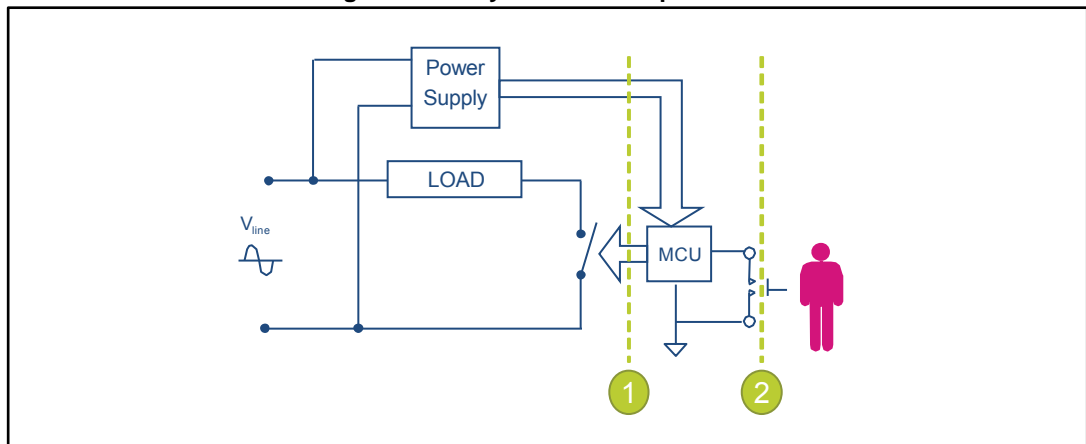

Figure 5 shows an insulation requirement in a single phase line application. The point 1 is the insulation of the AC switch: this is a functional insulation. The point 2 is a user interface insulation to avoid a possible user's electrical shock.

In safety regulations, like the international standard IEC 60335-1 for household and appliances or IEC 60601-1 for medical equipment, applications are indexed according to their insulation level: class I for those applications where earth is connected and class II for those applications without earth connection.

For examples, in case of appliances, (class I equipment), the insulation is required in the point 1 or in the point 2.

For the second case (class 2 equipment), both of point insulations are required or a single reinforced insulation either in point 1 or point 2 is needed.

Reinforced insulation is not usually preferred for cost reasons (it needs higher dielectric strength, higher surge capability, higher repetitive peak voltage etc.). That is why two basic protections are often used. This is also the reason why insulated Triac control is sometimes used for safety reasons in single phase applications (even if the Triac could be referenced to a power supply).

2.2 AC switch quadrants

To switch on an AC switch, like any bipolar device, a gate current must be applied between its gate pin (G) and its drive reference terminal (refer also to [AN3168](#)).

Then several cases occur:

- For an SCR, this gate current has to be positive (circulating from G to K)
- For a Triac and ACST, the gate current could be positive or negative (depending on the voltage applied to the device)
- For an ACS, the gate current has to be negative (circulating from COM to G)

Four triggering quadrants can be defined according to the polarity of the gate current and the polarity of the voltage applied across the device, as shown in [Figure 6](#). For an SCR, only a positive gate current can switch on the device. Thus, a single triggering quadrant (Q1) is considered for SCR devices.

Figure 6: Triac quadrant definition

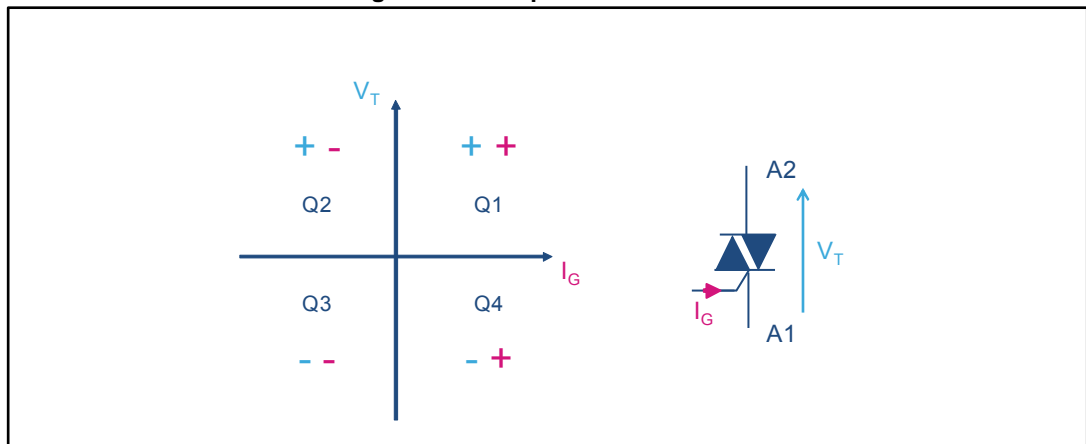

Table 1: Triggering quadrants for each AC switch family and class

Family	Class	Triggering quadrants			
		Q1	Q2	Q3	Q4
SCR	All	x	NA	NA	NA
Triac	Standard	x	x	x	x
	Snubberless and logic level	x	x	x	NA
	Snubberless high temperature	x	x	x	NA
ACS / ACST	ACS	NA	x	x	NA
	ACST	x	x	x	NA

As the triggering quadrants Q2 and Q3 are common to all Triacs and ACS / ACST devices, the control mode in Q2 and Q3 is recommended. Indeed, the replacement of one device by another one (for example, if an ACST is used in replacement of a standard Triac) is possible. Moreover, the triggering in Q4 is not advised because the triggering gate current is the highest. Also the di/dt at turn-on capability of Triacs is lower in Q4 compared to the other quadrants.

As the AC switch gate has not any insulated build-in part, the gate insulated circuit choice is then linked to the chosen AC switch device family and class.

2.3 Insulated control circuits

2.3.1 Opto-triac

Driving a Triac: [Figure 7](#) illustrates a single Triac driven by an opto-triac

Figure 7: Triac controlled with an opto-Triac

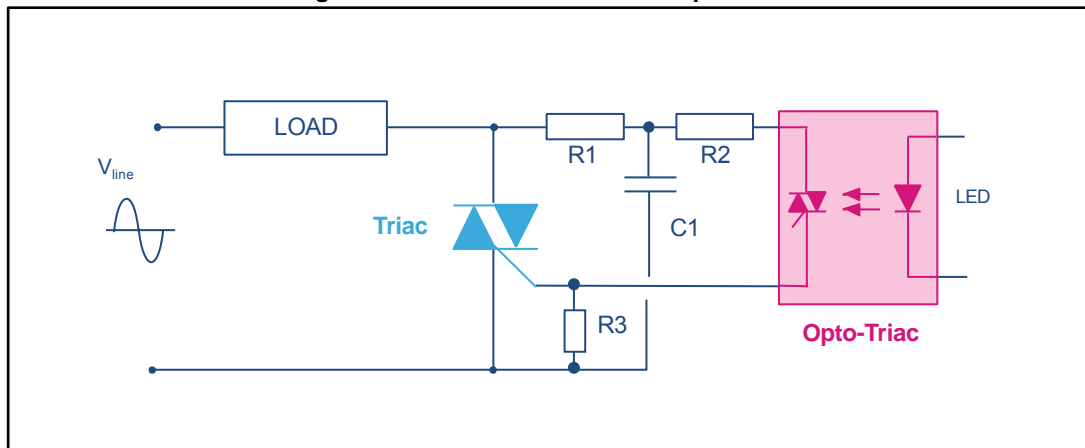

When the line voltage is positive and the opto-triac is controlled, current sunk from the line flows through R1, R2 and the Triac part of the opto-triac, to finally supply the Triac gate with a positive current G to A1. Then, the Triac triggers in Q1.

When the line voltage is negative, the current is inverted and then the Triac triggers in Q3.

It means that an opto-triac with an ACS device cannot be used as the ACS is a Q2 and Q3 quadrant device. Nevertheless, it is possible with all the other AC switch devices.

C1 increases this gate circuit immunity to high dV/dt and electrical fast transients (EFT). A 22 nF capacitor is recommended.

R1 reduces dI/dt at Triac turn-on, due to the C1 capacitor discharge. A 47 Ohm resistor is recommended.

R2 allows the current through the gate to be limited before the Triac turn-on. R2 value has to be so high to avoid the maximum current allowed both in the opto-triac (I_{TSM}) and the Triac gate (I_{GM}). At each line half-cycle, the Triac is OFF and the line voltage increases across the Triac until its IGT is reached. This voltage goes across the Triac before its triggering causes conducted EMI noise on the line, as described in the EN55014-1 European standard for household and appliances. Having a low value of R2 allows the Triac IGT with a low line voltage to be got and therefore EMI noise is limited. Thus, this R2 value comes from a trade-off among opto-triac I_{TSM} , Triac I_{GM} and EMI noise.

R3 increases circuit immunity to dV/dt and EFT. Indeed, the immunity increases when R3 is low. R3 value also depends on the Triac sensitivity (I_{GT}). As R3 derives opto-triac current, without this resistor the gate current is reached later on. This also causes EMI noise. Then R3 value is finally a trade-off between circuit immunity and EMI noise.

The advantage is the low number of components used to achieve the insulated control compared to other solutions presented in this application note.

Drawbacks are, first of all, the passive component value definition to obtain a good trade-off among Triac I_{GT} , dV/dt immunity and EMI noise disturbance. Secondly, this circuit is not able to drive low RMS current loads. In fact, once the Triac is in ON-state, no more current flows through the opto-triac. The gate current is then applied to the Triac triggering event only. As a consequence, if the gate current is removed while the load current has not reached the Triac latching current (I_L), the Triac is turned OFF (refer to [AN303](#) for latching current concern).

Driving two SCRs

Back-to back SCRs are the preferred choice in case of applications requiring a strong turn-off capability, indeed, they work like a Triac with infinite $(dI/dt)_c$.

Besides, they are used without any mechanical relay, in solid-state-relay applications, [Figure 8](#) gives the schematic to drive two SCRs in back-to-back with a single opto-triac.

A resistor/capacitor snubber is placed in parallel with both SCRs and opto-triac to keep a high dV/dt immunity despite of the poor opto-triac intrinsic immunity (refer to [AN437](#) for RC snubber design). Furthermore, a Transil device is added to protect this circuit against possible line overvoltages (refer to [AN1966](#) for overvoltage protection with Transil).

Figure 8: SCRs controlled by an opto-triac

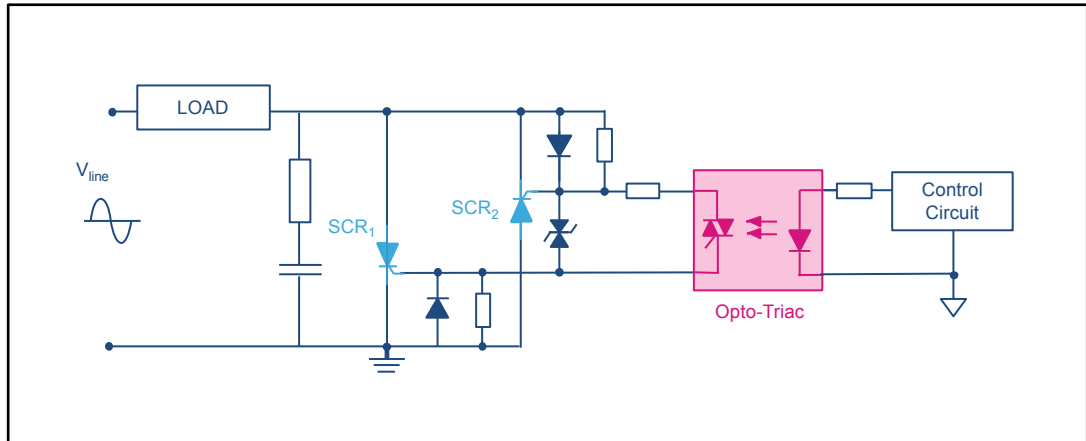

The major issue using an opto-triac command (both with back-to-back SCR and Triac solutions) for a hybrid relay is occurred on the stop phase. Actually, the opto-triac circuit needs a minimum voltage across it to have the required gate current trig the Triac or SCR. When the mechanical relay is ON, no current flows through the gate, and at relay opening, line voltage rises until SCR/Triac turn-ON (until the gate current has reached the SCR/Triac I_{GT}). This pulse voltage between relay turn-off and Triac turn-on causes EMI noise (same noise as explained for V_{FP} in [Section 3](#)).

2.3.2 Transformer

[Figure 9](#) shows a Triac controlled by a pulse transformer.

Figure 9: Triac controlled by a pulse transformer

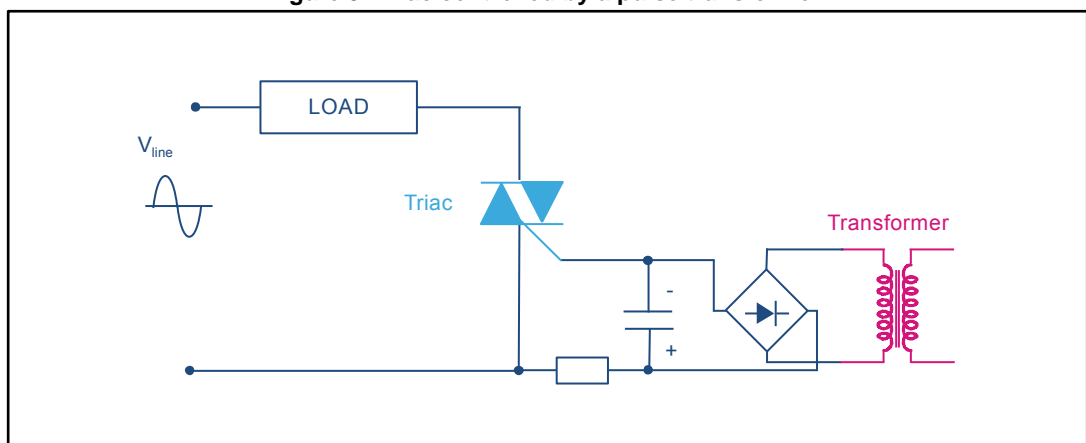

By using a diode bridge and a polarized small capacitor, the Triac can be triggered in quadrants Q2 and Q3, allowing all family of AC switch to be used. Please note that the diode bridge and the capacitor can be inverted to drive an SCR to quadrant Q1.

The main advantage, besides the triggering quadrants, is that the transformer can be controlled by pulses in PWM, and according to the capacitor value, the Triac is controlled with a DC gate current. It causes that low RMS loads can be triggered with no Triac latching issues and PWM control saves energy.

Additionally, the gate capacitor allows the Triac immunity to be increased to EFT. The gate resistor is absolutely mandatory to maintain a good di/dt reliability level (refer to [AN4030](#)).

Drawback is the cost compared to a semiconductor opto-device, especially the expensive ferrite core.

2.3.3 Opto-transistor

In [Figure 10](#), the Triac is controlled by an opto-transistor in quadrants Q2 and Q3.

Figure 10: Triac controlled by an opto-transistor

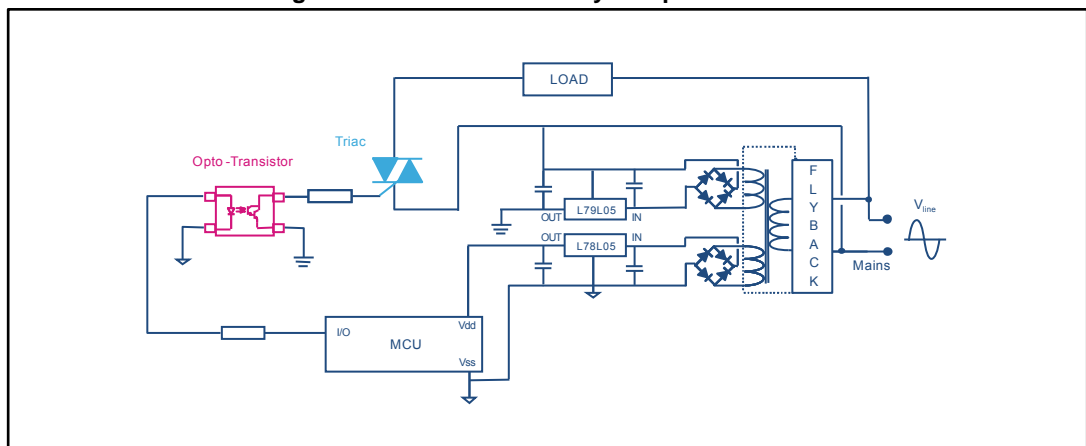

With this insulation circuit, an additional power supply is needed to provide the gate current. [Figure 10](#) shows a low cost solution, that is: an additional winding of a transformer of an SMPS. To implement an additional power supply dedicated to the gate current, a capacitive power supply can be used. The mandatory power supply is the main drawback of a control by opto-transistor.

The advantage is that the applied Triac gate current can be a DC current, allowing low RMS load control.

2.4 Solutions

In [Table 2](#), the advantages and drawbacks of each solution of insulated control circuit are reported.

Table 2: Insulated control circuits advantages and drawbacks

Insulated control circuit	Advantages	Drawbacks
Opto-triac	Size, low number of components	EMC (dV/dt immunity and EMI noise), no low current loads
Transformer	Allowed low current loads, EMC	Price, size

Insulated control circuit	Advantages	Drawbacks
Opto-transistor	Allowed low current loads, EMC	Needs additional PS (if not available), no possibility to drive back-to-back SCR

2.5 Insulated control versus hybrid relay applications

The following table summarizes the insulated control circuit possibilities according to the hybrid relay application power grid, power level and AC switch type. This is a non-exhaustive list of application examples, given for illustration.

Power ranges are given for information and could be slightly different for specific applications. RMS powers are given for a 230 V line voltage (between phase and neutral for a single-phase grid and then 400 V between two phases in a 3-phase grid network). It could be easily transposed for a single phase 110 V grid or a higher 3-phase voltage for industrial purposes. Insulated control circuits are recommended (yes) or not (no) according to application requirements and advantages and drawbacks of each circuits mentioned in [Section 2.3](#). However, specific applications and circuits could require different choices.

Table 3: Insulated circuits versus hybrid relay applications

Power grid	AC switches	Power	H/R application examples	Opto-triac	Transf.	Opto-transistor
Single phase	Triac	< 100 W	<ul style="list-style-type: none"> Smart-plug (halogen, CFL and LED lamps) 	Yes	No	No
		< 500 W	<ul style="list-style-type: none"> Converter inrush current limiter Power tools (hand screwdriver, sander) Kitchen tools (ice crusher, soya milk maker) Liquid pump 	Yes	No	No
		< 7.4 kW	<ul style="list-style-type: none"> Room heater Water heater Power tools (drill, glue gun, saw) Kitchen tools (kitchen aid, blender) Smart-plug (heater, coffee machine) Fan UPS Oven 	Yes	Yes	Yes
	SCR	< 3.7 kW	<ul style="list-style-type: none"> Instantaneous water heater and boiler Welding equipment Fan 	Yes	Yes	No
3-phase	Triac	< 500 W	<ul style="list-style-type: none"> Pumps (liquid, air) 	No	Yes	Yes

Power grid	AC switches	Power	H/R application examples	Opto-triac	Transf.	Opto-transistor
		> 7.4 kW	<ul style="list-style-type: none"> Industrial motor starter pumps (liquid, air) compressors Fan (air conditioner, dryer) 	Yes	Yes	Yes
	SCR	> 3.7 kW	<ul style="list-style-type: none"> Industrial motor starter Instantaneous water heater Industrial heating Industrial machine (welding, printing, packing, weaving) Fan 	Yes	Yes	No

To sum-up the [Table 3](#), opto-triac circuit is not recommended for low power loads with Triac (for latching issues) and is not recommended to drive a single SCR (as this is a Q1/Q3 quadrant gate circuit), but drives two SCRs in back-to-back for high power applications. It is not recommended for a hybrid relay as it causes EMI noises during the stop phase. This is the cheapest gate circuit.

Triac can be driven by an opto-transistor but an additional power supply is needed as explained in [Section 2.3.2](#). This means that it is not recommended for an SCR in back-to-back because it needs two additional power supplies.

Transformer can be used for all applications, but this is the most expensive solution (except if an additional power supply is not already available for opto-transistor driving).

Once the AC switch gate circuit (insulated or not) is chosen, the next concern regarding the hybrid relay design is the conducted EMI noise of this kind of application.

3 EMI conducted noise management

Although the gate circuit is defined in an appropriate manner and allows the electromagnetic interference noise to be highly decreased, it is still an issue at hybrid relay turn-off. Indeed, a disturbance still occurs at the conduction transition from the mechanical relay to the Triac. Such a transition only occurs at hybrid relay turn-off. The EN 55014-1 limit, to be applied for a discontinuous disturbance, depends on the repetition (or "click") rate, i.e. on the hybrid relay operating frequency, and on the disturbance duration.

The following waveforms and measurements of voltages and currents are performed with a Triac T2550-12G (50 A – 1200 V) used for 3-phase motor starter applications, as seen in [Section 1.3.4](#).

3.1 V_{FP} phenomenon

[Figure 11](#), part a shows the voltage spike occurring during this phase; it happens precisely when the relay is switched OFF and then when the Triac starts conducting, (i.e. when the entire load current suddenly switches from the relay to the Triac). [Figure 11](#), part b illustrates a zoom-in view of the current rise through the Triac. The di_T/dt rate is close to 8 A/ μ s. As the Triac was triggered but it did not conduct (as the entire current still circulated through the mechanical relay), its silicon substrate presents high resistivity when the current begins flowing. This high resistivity leads to a high peak voltage, which equals 11.6 V on the measurement performed with a T2550-12G shown in [Figure 11](#).

This voltage spike, called V_{FP} , is an undesirable voltage variation across the hybrid relay and then across the load, and consequently a load current variation. This current variation on line is a conducted disturbance considered as a discontinuous disturbance by the EN 55014-1 standard.

Figure 11: Hybrid relay turn-off (a) – zoom on Triac turn-on (b)

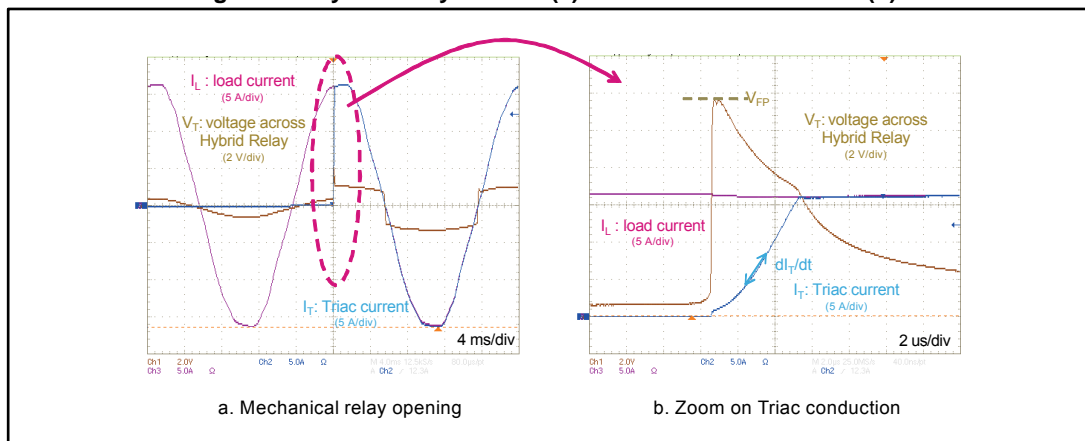

After the Triac has started to conduct, both top and bottom P-N junction of the Triac silicon structure inject minority carriers into the substrate. This injection allows the substrate resistivity to be modulated and then to be decreased, and the on-state voltage to decrease down to approximately 1-1.5 V.

This phenomenon is the same phenomenon that leads to a peak voltage drop across a PIN diode and that turns on with a high rate of current increase. This is the reason why a PIN diode datasheet gives a V_{FP} peak voltage, depending on the applied di/dt , which can have

an impact on an application efficiency if it occurs at a high frequency. For an HR application, this V_{FP} voltage occurs only once at HR turn-off and does not have to be considered to evaluate the power losses.

It should be also noted that, since the V_{FP} phenomenon is due to the time needed to modulate the substrate resistivity by injecting minor carriers, this voltage is higher for a 1200 V device than for a 800 V Triac, like a T2550-8. So the blocking voltage of the switch has to be selected with care as a too high margin leads to a higher peak voltage at turn-on.

Even if the measured peak voltage is higher than the one measured with the opto-triac circuit, EMI content is reduced as this phenomenon occurs only once per cycle, at each hybrid relay turn-off, and lasts just few microseconds. Because of this, a pulse-transformer driving circuit is preferred despite its bigger size and its higher cost due to expensive ferrite cores.

3.2 Design advice to decrease EMI noise

To reduce the V_{FP} phenomenon on hybrid relay applications, a few easy tips can be followed on the control circuit.

Triac triggering quadrant: the most effective tip is to control the relay to switch OFF during negative current conduction. Indeed, the V_{FP} phenomenon is lower for a negative current. [Figure 12](#) shows the V_{FP} voltage measured for the same test conditions as that of [Figure 11](#), part b, but for a negative current. It can be seen that the V_{FP} is reduced by 2, from 11.6 V for a positive current to 5.5 V here. The lower V_{FP} voltage for negative polarity is due to the easier silicon structure turn-on in quadrant 3 compared to quadrant 2 (positive A2-A1 voltage and negative gate current).

Figure 12: V_{FP} for a negative switched current

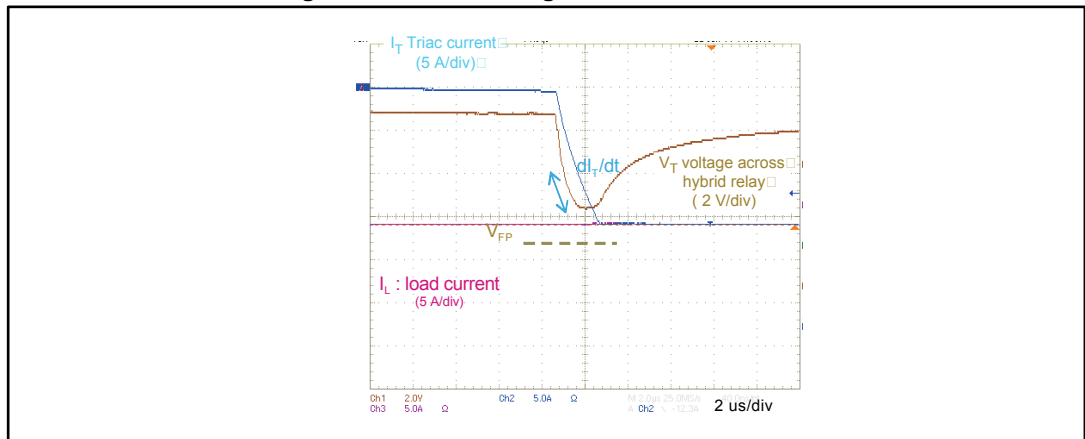

Gate current level: another piece of advice consists of increasing the Triac gate current. For example, with a T2550-12G Triac, the V_{FP} can be reduced by 2 to 3, especially for a positive switched current, when a 100 mA gate current is applied instead of applying the specified I_{GT} level (50 mA) only

Furthermore, it is generally advised to apply at least twice the device I_{GT} to ensure a good triggering of the Triac at cold temperature, especially at application start-up when the junction temperature of the Triac is at ambient temperature. [Figure 13](#) comes from the T2550-12 datasheet and shows that device I_{GT} level is higher at low temperature (at $-40\text{ }^{\circ}\text{C}$, the I_{GT} level is up to 2.3 times the I_{GT} at $25\text{ }^{\circ}\text{C}$).

Figure 13: Relative variation of gate trigger current versus junction temperature

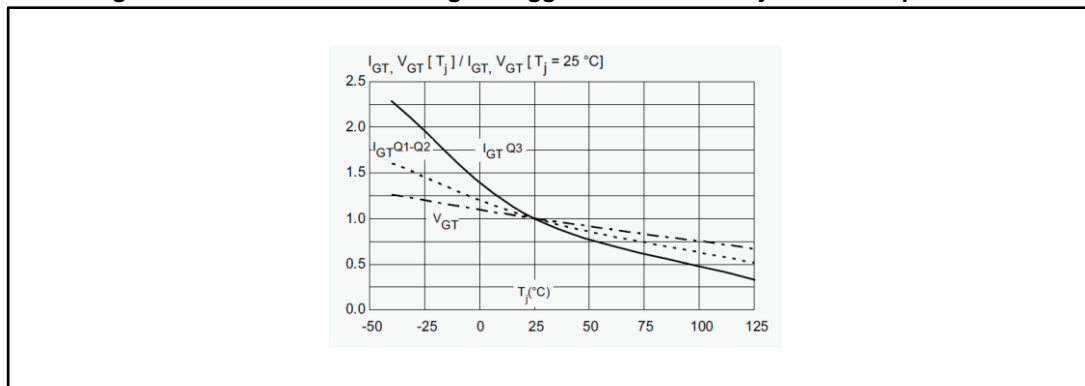

Relay opening at ZCS: another solution to reduce V_{FP} voltage is to try to open the relay close to the zero-current crossing point. Indeed, limiting the switched current also means to limit the applied di_T/dt at Triac turn-on. Of course, to implement such a solution, a mechanical relay with a turn-off time lower than few ms has to be selected.

di_T/dt reduction: as explained previously, higher is the di_T/dt , higher is the V_{FP} spike. Reducing the di_T/dt is possible by adding an inductor in series to the Triac. A short PCB track between the mechanical relay and the Triac is then not advised here. The typical value for this inductor is few tens of μH , to be fine-tuned according to the di/dt value to be reduced.

All these tips give key information to decrease V_{FP} , but this voltage spike is highly depends on the device technology and process. That is why EMI conduction noise has to be validated by test.

4 Conclusion

This document describes how to design an SCR- or Triac-based hybrid relay. The main advantages to implement this hybrid switch to drive an AC load, among others, are: it decreases power losses, manages inrush current or increases application immunity.

Hybrid relays cover a wide range of application scopes. From small appliances to high wattage industrial motor starter. [Table 3](#) gives a good view of this application range.

SCR/Triac insulation control is mandatory in a lot of cases for safety purposes or in 3-phase applications. The three main insulated gate circuits (opto-triac, transformer and opto-transistor) are described by specifying advantages and drawbacks, which allow designer to make the right choice for his own application, taking into account the trade-off between cost and performance (dV/dt, EMI noise).

Finally, whatever the gate circuit is, there is a voltage spike at hybrid relay turn-off - due to Triac VFP - that causes EMI noise. A piece of advice is given to decrease this noise (turn-on quadrant, I_{GT} level, relay opening synchronization or dI/dt reduction).

Further information can be found in the following application notes:

- [AN4030](#): Explains the impacts of a capacitor connected between device gate and drive reference.
- [AN3168](#): Explains SCR/Triac Triggering quadrants.
- [AN303](#): Explains the latching concern of SCR/Triac devices.
- [AN4606](#): Gives Inrush Current Limiter circuits and design tips.
- [AN437](#): Gives R/C snubber design rules.
- [AN1966](#): Explains how to implement an overvoltage protection with a Transil.

5 Revision history

Table 4: Document revision history

Date	Revision	Changes
06-Mar-2017	1	First release.

IMPORTANT NOTICE – PLEASE READ CAREFULLY

STMicroelectronics NV and its subsidiaries ("ST") reserve the right to make changes, corrections, enhancements, modifications, and improvements to ST products and/or to this document at any time without notice. Purchasers should obtain the latest relevant information on ST products before placing orders. ST products are sold pursuant to ST's terms and conditions of sale in place at the time of order acknowledgement.

Purchasers are solely responsible for the choice, selection, and use of ST products and ST assumes no liability for application assistance or the design of Purchasers' products.

No license, express or implied, to any intellectual property right is granted by ST herein.

Resale of ST products with provisions different from the information set forth herein shall void any warranty granted by ST for such product.

ST and the ST logo are trademarks of ST. All other product or service names are the property of their respective owners.

Information in this document supersedes and replaces information previously supplied in any prior versions of this document.

© 2017 STMicroelectronics – All rights reserved